

Action code: **WHEN CONVENIENT**

**Guidelines for Operation on Fuels with less than 0.1% Sulphur**

SL2014-593/DOJA  
December 2014

**Concerns**

Owners and operators of MAN B&W two-stroke marine diesel engines and Holeby GenSets.

**Summary**

MAN Diesel & Turbo recommends fuels with a viscosity of min. 2 cSt at engine inlet, and change-over to low-BN cylinder lube oils immediately when changing over to fuels with less than 0.1% S.

Dear Sirs

The new MARPOL Annex VI ultra-low-sulphur fuel oil regulations coming into force as of 1 January 2015 introduce a significant regulatory change with respect to the maximum permissible content of sulphur (S) in marine fuels in designated sulphur emission control areas (SECAs), from max. 1.0% S to max. 0.1% S.

This change makes it even more important than before to know what is bunkered and to keep the crew informed on specific challenges and the appropriate actions. Careful monitoring of the cylinder condition must also be carried out and followed by the proper action.

The enclosed paper: "Guidelines for Operation on Fuels with less than 0.1% Sulphur", provides guidelines and recommendations on how to ensure safe and reliable operation on fuels with less than 0.1% sulphur. The following key subjects are described:

- Low-BN cylinder oils – how and when to apply low-BN oils
- ISO 8217 and new fuels with less than 0.1% S (ULSFO) – key characteristics of different standard fuel grades.
- Viscosity and fuel pump pressure - the viscosity of the fuel should be kept above 2 cSt at engine inlet, and the fuel pumps must be kept in adequate condition.

This new SL replaces SL09-515 "Guidelines for Operation on Distillate Fuels – Low-viscosity fuels". For questions or inquiries regarding the recommendations in this letter, contact our Operation Department at: leo@mandieselturbo.com

Yours faithfully



**Mikael C Jensen**  
Vice President  
Engineering



**Stig B Jakobsen**  
Senior Manager  
Operation



Encl.

**Head office (& postal address)**  
**MAN Diesel & Turbo**  
Tegholmegade 41  
2450 Copenhagen SV  
Denmark  
Phone: +45 33 85 11 00  
Fax: +45 33 85 10 30  
info-cph@mandieselturbo.com  
www.mandieselturbo.com

**PrimeServ**  
Tegholmegade 41  
2450 Copenhagen SV  
Denmark  
Phone: +45 33 85 11 00  
Fax: +45 33 85 10 49  
PrimeServ-cph@mandieselturbo.com

**Production**  
Tegholmegade 35  
2450 Copenhagen SV  
Denmark  
Phone: +45 33 85 11 00  
Fax: +45 33 85 10 17  
manufacturing-dk@mandieselturbo.com

**Forwarding & Receiving**  
Tegholmegade 35  
2450 Copenhagen SV  
Denmark  
Phone: +45 33 85 11 00  
Fax: +45 33 85 10 16  
shipping-cph@mandieselturbo.com

**MAN Diesel & Turbo**  
Branch of MAN Diesel & Turbo SE,  
Germany  
CVR No.: 31611792  
Head office: Tegholmegade 41  
2450 Copenhagen SV, Denmark  
German Reg.No.: HRB 22056  
Amtsgericht Augsburg

# Guidelines for Operation on Fuels with less than 0.1% Sulphur

## Introduction

This paper is a guideline for owners, operators and crews on how to prepare for the changes in fuel characteristics and operate in compliance with the new sulphur limits in sulphur emission control areas (SECAs) as of 1 January 2015. The SECA's currently included are the Baltic Sea, The North Sea, the English Channel and waters within 200 nautical miles from the coast of USA, the coastal waters around Puerto Rico and the U.S. Virgin Islands (the US Caribbean ECA) and Canada.

The sulphur (S) limit will decrease from max. 1.0% S to max. 0.1% S. This means that in order to comply with the legislation operators will have to use either a fuel with less than 0.1% sulphur, e.g. distillate, other fuels with less than 0.1% S, or install a scrubber.

MAN Diesel & Turbo recommends fuels with a viscosity of min. 2 cSt at engine inlet and change-over to low-BN cylin-

der lube oils immediately when changing over to fuels with less than 0.1% S.

MAN B&W two-stroke engines and Holeby GenSets are optimised to operate on heavy fuel oil (HFO).

However, fuels with less than 0.1% S can be used when appropriate actions are taken:

- The viscosity of the fuel should be kept above 2 cSt at engine inlet
- When operating on less than 0.1%S fuels: Switch immediately to low-BN oil (15-40 BN) on the two-stroke engine
- Know what you are bunkering and inform the crew on the specific challenges
- Always remove cat-fines
- Monitor the cylinder condition and act accordingly

## Contents

1. Low-BN cylinder oils .....	2
2. Standard of marine fuels: ISO 8217-2012 .....	5
3. New fuels with less than 0.1% S .....	5
4. Viscosity .....	6
5. Fuel pump pressure .....	9
6. Lubricity .....	10
7. Cat-fines (Al+Si) .....	10
8. Fuel temperature: pour point .....	12
9. Compatibility between fuels .....	12
10. Fuel change-over procedures .....	13
11. Low-sulphur biofuel .....	15
12. Summary .....	16
Appendix .....	16

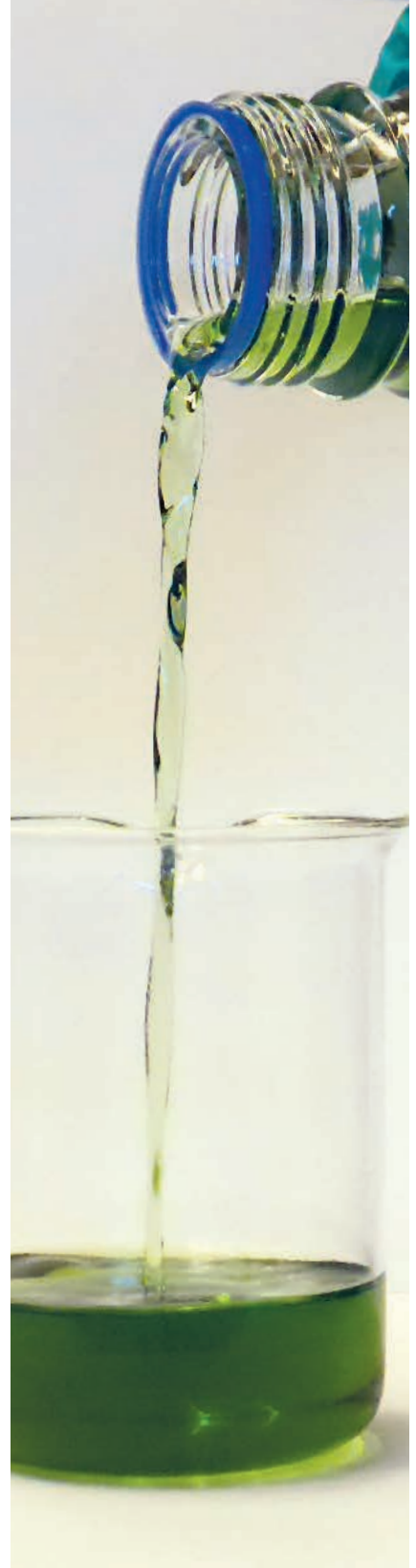

## 1. Low-BN cylinder oils

Until now, marine low speed engines and their lubricants have been optimised for operation on heavy fuel oil (HFO) with a high sulphur (S) content. During combustion, the S is converted to sulphur trioxide (SO<sub>3</sub>). In combination with water from the combustion and the scavenge air, SO<sub>3</sub> forms sulphuric acid (H<sub>2</sub>SO<sub>4</sub>). When the liner temperature drops below the dew point of sulphuric acid and water, a corrosive mixture condenses on the liner wall. The high-alkaline lubricants (high-BN oils) neutralise the acid and prevent corrosion of piston rings and cylinder liner surfaces.

When operating on fuels with less than 0.1 % S, such as distillates, ultra-low-sulphur fuel oil (ULSFO) with less than

0.1% S, LNG, methanol, ethane and LPG, only small amounts of sulphuric acid are formed in the combustion chamber. The cylinder lube oil additives are then not used for the designed purpose and they tend to build up as deposits. These deposits may disturb the lube oil film and obstruct the piston ring movement, which could lead to micro-seizures on the piston rings and liner and increase the risk of scuffing. Deposit formation and the total lack of corrosion increase the risk of bore-polishing, which could also lead to increased wear and scuffing. For engines operating continuously on fuels with less than 0.1% S, we recommend to install piston rings with cermet coating on all four rings to reduce the risk of seizures and scuffing.

### Lubrication strategy

Complications caused by deposit build-up can be avoided by using cylinder lube oils with a low amount of deposit-forming additives and good detergency properties (low-BN oils) and by operating at the lowest recommended cylinder lube oil feed rate. The feed rate should be decreased to the minimum feed rate specified in our latest service letters.

The general lubrication strategy is to use a high-BN cylinder oil (70-100 BN) when operating on high-sulphur fuels and a low-BN oil (15-40 BN) when operating on low-sulphur fuel. An overview of how to choose a suitable cylinder lube oil is shown in Fig. 1.

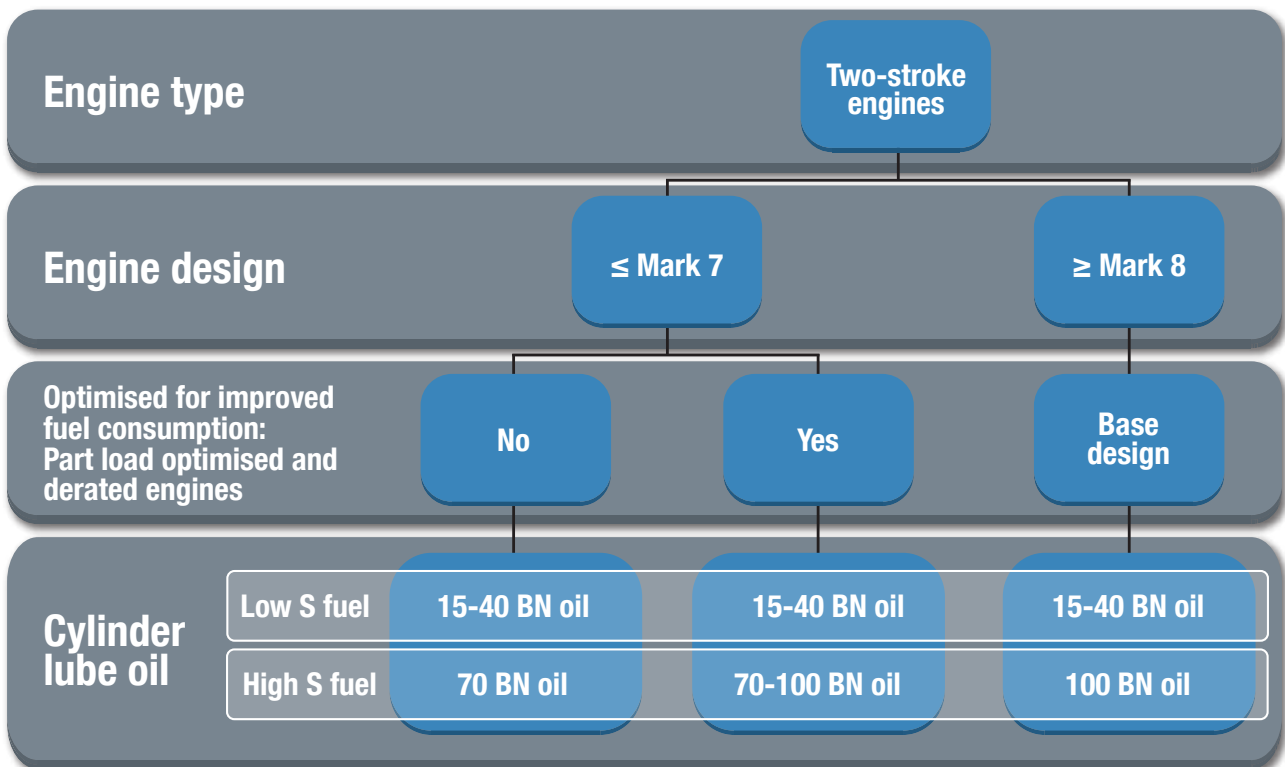

Fig. 1: General overview of cylinder lube oils and how to choose a suitable cylinder lube oil. Low S fuel = low-sulphur fuel, incl. distillates, new types of fuels with less than 0.1% S, LNG, methanol, ethane and LPG. High S fuel = high-sulphur fuel.

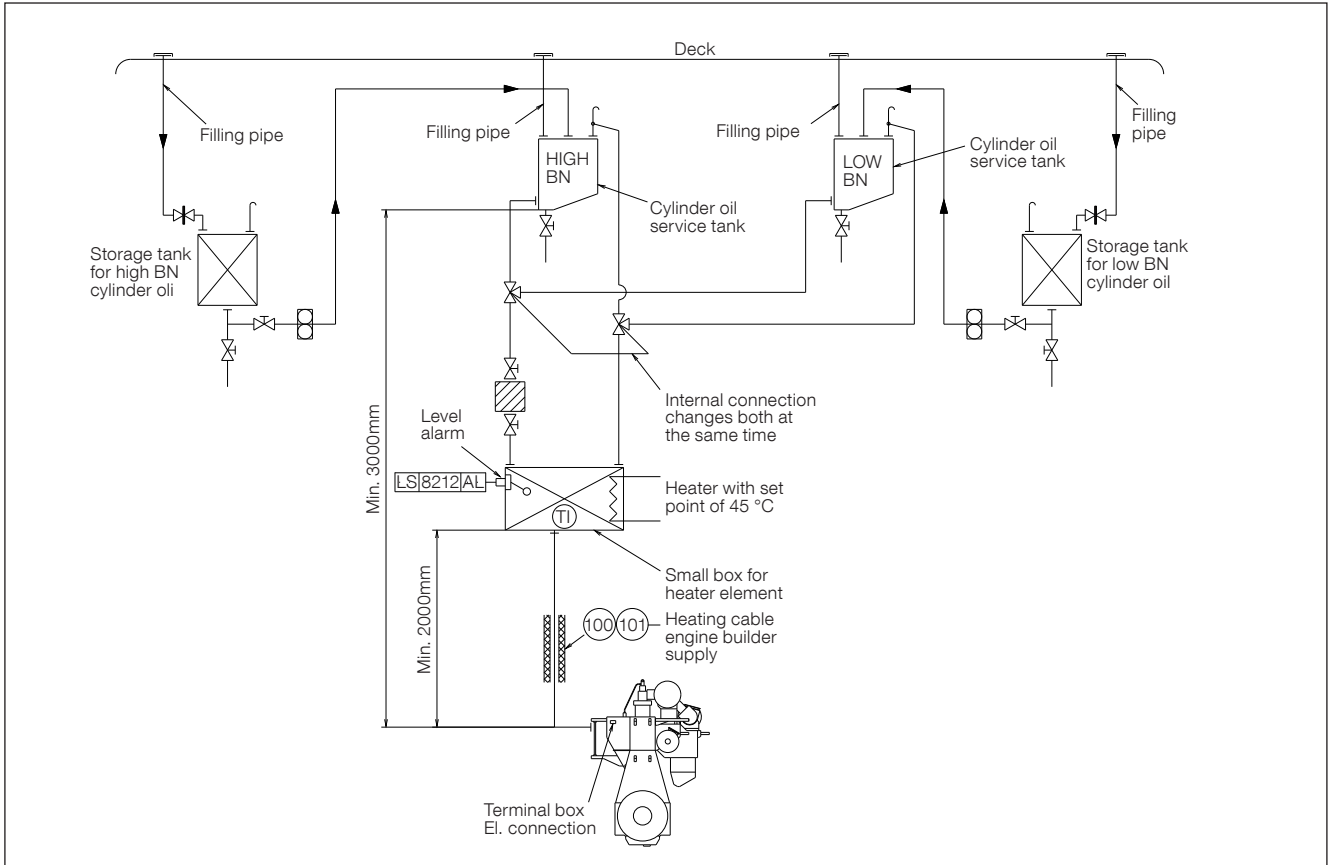

Fig. 2: Recommendation for cylinder lubrication system for ME engines. Similar system should be installed on MC engines using the Alpha Lubricator or mechanical lubricators

When switching to fuels with less than 0.1% S, we recommend switching to a low-BN cylinder oil at the same time. We do not recommend the use of a high-BN cylinder oil when running on fuels with less than 0.1% S. This recommendation is valid for all engine types and Mark numbers, and for all lubricator types: electronic (ME and Alpha Lubricator) and mechanical (e.g. Hans Jensen), see also our service letters on cylinder lubrication, SL2014-587 (electronic lubricators) and SL2012-553 (mechanical lubricators).

To support this, we have for many years recommended to install two service tanks, one for low-BN oil and one for high-BN oil (Fig. 2).

There are low-BN cylinder lube oils with different BN levels on the market today. Currently, there are three different low-BN levels: 17, 25 and 40 BN. However, development continues and in the future there could be oils with other BN levels. Good performance of the low-BN oil is the most important factor.

As the neutralising capacity of these oils varies with the BN, the max. fuel S con-

tent also varies. We recommend using them for fuels within the below-specified fuel S content interval (Table 1).

When using the low-BN oils for higher sulphur fuels (e.g. 0.5% S fuel) we recommend dosing the oils at higher feed rates as according to the normal ACC or feed rate factor (FRF) strategy for electronic lubricators (see Appendix or CLO Advisor).

Cylinder lube oil BN	Min. % S fuel	Max. % S fuel
15-24	0	0.5
25-34	0	1.0
35-40	0	1.5

Table 1 Fuel S applications for low-BN cylinder oils

We expect that the lowest BN oils (17 and 25 BN) will perform best, both in short- and long-term operation, on fuels with less than 0.1% S. However, 40 BN oils may perform satisfactorily for a shorter time on such fuels, and we recommend a maximum operation time of 1-2 weeks on 40 BN oils, see Table 2.

Used oil samples (also called drain oil or scrape down oil) taken from the engine through the scavenge bottom drain can be used for cylinder condition evaluation. Drain oil analysis can show whether the cylinder condition is within the normal range or whether action must be taken, e.g. lowering the feed rate towards minimum dosage or removing cat-fines from the fuel, see latest service letter or the CLO Advisor.

Operation on fuels with less than 0.1% S induces less corrosion on the liners, so we expect normal wear values for iron (Fe) to be in the range of 50-100 ppm and the remaining BN to be 5-10 BN less than the original BN value. Guiding values for alarm levels are listed in Table 3.

Table 4 shows examples of low-BN cylinder oils presently available in the international market. High- and low-BN oils are listed in "Oils for Marine Two-Stroke Engines" (case no. 50921-2014).

### Summary 1: low-BN cylinder oils

- Recommendations are valid for all engine types and Mark numbers
- Use low-BN oil (15-40 BN) when operating on fuels < 0.1% S
- When switching to < 0.1% S fuels: switch immediately to low-BN oil
- Operation on < 0.1% S fuels: optimise the feed rate towards minimum (0.6-0.7 g/kWh) for electronic lubricators. Use the fixed feed rate for mechanical lubricators
- Two service tanks: one for high-BN oil and one for low-BN oil
- Monitor the cylinder condition and act accordingly

Cylinder lube oil BN	Recommended time of operation on fuels < 0.1% S
15-30	Short and long term service
30-40	Less than 1-2 weeks

Table 2 Recommended time of operation on fuels with less than 0.1% S

Cylinder lube oil BN	Scavenge drain oil – Guiding values	
	Remaining BN	Fe, ppm
15-24	> 5-10	< 100-200 depending on engine type
25-34	> 5-15	< 100-200 depending on engine type
35-40	> 10-20	< 100-200 depending on engine type

Table 3 Guiding alarm levels for scavenge drain oils for fuels with less than 0.1% S

Oil company	Oil name	BN level
Aegean	Alfacylo 540 LS	40
Castrol	Cyltech 40SX	40
Chevron	Taro Special HT LF	25
	Taro Special HT LS 40	40
ExxonMobil	Mobilgard 525	25
Gulf Oil Marine	GulfSea Cylcare ECA 50	17
	GulfSea Cylcare DCA 5040H	40
Indian Oil Corp.	Servo Marine LB 1750	17
JX Nippon Oil & Energy	Marine C405	40
Lukoil	Navigo 40 MCL	40
Shell	Alexia S3	25
Sinopec	Marine Cylinder Oil 5040	40
Total	Talusia LS 25	25
	Talusia LS40	40

Table 4 Examples of low-BN cylinder oils on the international market

## 2. Standard of marine fuels: ISO 8217-2012

The current ISO 8217-2012 standard for marine fuels specifies three different distillate grades (DM) and a number of residual grades (RM). Table 5 shows the key characteristics for fuels which may fulfil the maximum 0.1% sulphur limit.

## 3. New fuels with less than 0.1% S

New types of 0.1% S fuels are entering the market in response to the 0.1% S SECA limit. These new fuel types are usually referred to as ultra-low-sulphur fuel oils (ULSFO), which are usually not traditional distillates, but blended products or products from refinery streams that have not previously been utilised extensively in marine fuels. MAN Diesel

& Turbo expects that these fuels are well-suited for MAN B&W two-stroke engines as well as Holeby GenSets. However, as always, it is important to read and act on the fuel suppliers' recommendations, manuals and best practise sheets to ensure that the fuel can be used safely and efficiently. Some of the fuels are in the ISO 8217 DM-range and some in the RM-grades.

Key characteristics	Unit	Limit	DMA	DMZ	DMB	RMA 10	RMB 30	RMD 80
Density at 15°C	kg/m <sup>3</sup>	Max.	890	890	900	920	960	975
Viscosity at 40°C	mm <sup>2</sup> /s (cSt)	Min.	2.00	3.00	2.00	-	-	-
		Max.	6.0	6.0	11.0	-	-	-
Viscosity at 50°C	mm <sup>2</sup> /s (cSt)	Max.	-	-	-	10.0	30.0	80.0
Sulphur	% m/m	Max.	1.50	1.50	2.00	max. 0.1% in SECA		
Flash point	°C	Min.	60	60	60	60	60	60
Pour point (winter)	°C	Max.	-6.0	-6.0	0.0	0	0	30
Acid number	mg KOH/g	Max.	0.5	0.5	0.5	2.5	2.5	2.5
Al+Si	ppm m/m	Max.	-	-	-	25	40	40
Lubricity	µm	Max.	520	520	520	-	-	-

Table 5 Key characteristics of fuels in the ISO standard for marine fuels, ISO 8217-2012

The general characteristics of ULSFO fuels are:

- They might have a higher viscosity than ISO 8217 distillate grades, see Section 4.
- They might contain cat-fines (Al+Si), see Section 7.
- They might have a high pour point, see Section 8.
- There could be compatibility issues when blending with other fuels, see Section 9.

Key characteristics of examples of new types of fuels with less than 0.1% S can be found in Table 6 below. The areas of concern are marked in yellow.

**Summary 2 and 3: ISO 8217 and new fuels with less than 0.1% S (ULSFO)**

- Consult the current ISO 8217 standard for marine fuels for key characteristics of different standard fuel grades
- Viscosity might be higher than distillates for ULSFO
- Cat-fines: remove them using the cleaning system
- Pour point might be higher than distillates for ULSFO. Keep the temperature above the pour point
- Compatibility: use dedicated tanks and do not mix different fuels
- Change to a low-BN cylinder oil
- Know what you are bunkering and inform the crew about appropriate actions

**4. Viscosity**

The recommended fuel viscosity range for MAN B&W two-stroke engines at engine inlet can be seen in Table 7. The lower fuel viscosity limit is 2 cSt. Figures 3-5 show typical viscosity and temperature relationships for marine fuels with very low viscosity and with medium viscosity. For the low viscosity grades, care must be taken not to heat the fuel too much and thereby reduce the viscosity.

Range	Fuel viscosity at engine inlet
Min.	2 cSt
Normal	10-15 cSt
Max.	20 cSt

Table 7 Recommended fuel viscosity range at engine inlet

Key characteristics	Unit	Limit	Supplier A	Supplier B	Supplier C	Supplier D	Supplier E
Density at 15°C	kg/m <sup>3</sup>	Max.	895-915	870-930	928	910	845
Viscosity at 40°C	mm <sup>2</sup> /s (=cSt)	Min.	40	-	45	-	-
		Max.	75	-	65	-	-
Viscosity at 50°C	mm <sup>2</sup> /s (=cSt)		-	8-25	30-40	65	8.8
Sulphur	% m/m	Max.	0.1	0.1	0.1	0.095	0.03
Flash point	°C	Min.	70	60-80	70	60	70
Pour point (winter)	°C	Max.	15-30	18-21	20-25	20	21
Acid number	mg KOH/g	Max.	0.1	0.1-0.2	2.5	2.5	0.04
Al+Si	ppm m/m	Max.	<0.3	12-15	10-20	17	<1
Lubricity	µm	Max.	<320	-	-	520	328

Table 6 Key characteristics of examples of new types of fuels with less than 0.1 % S (ULSFO)

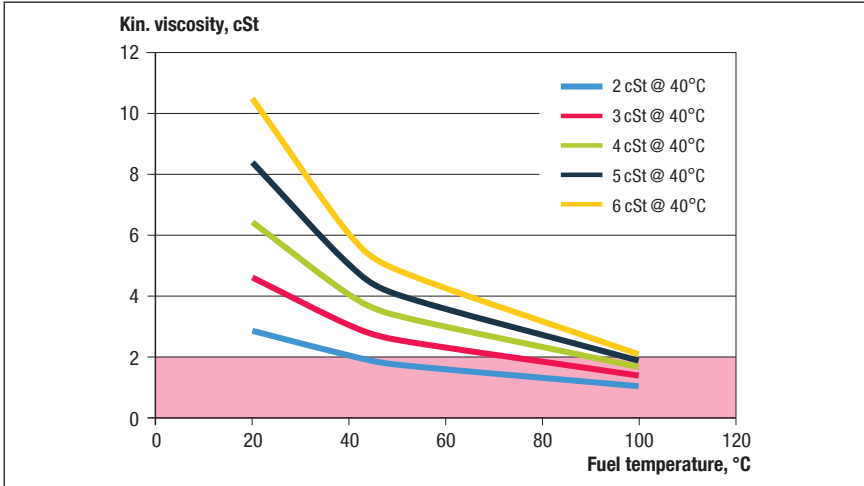

Fig. 3: Temperature – viscosity relationship for very low viscosity fuels

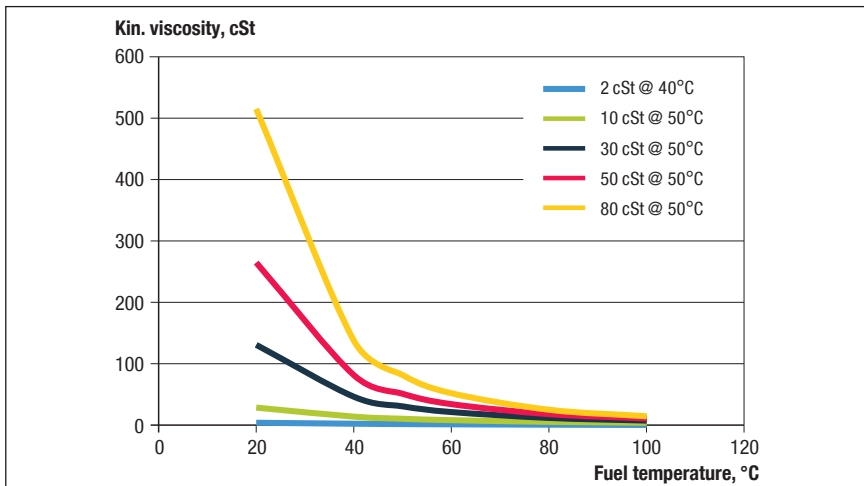

Fig. 4: Temperature – viscosity relationship for low-medium viscosity fuels

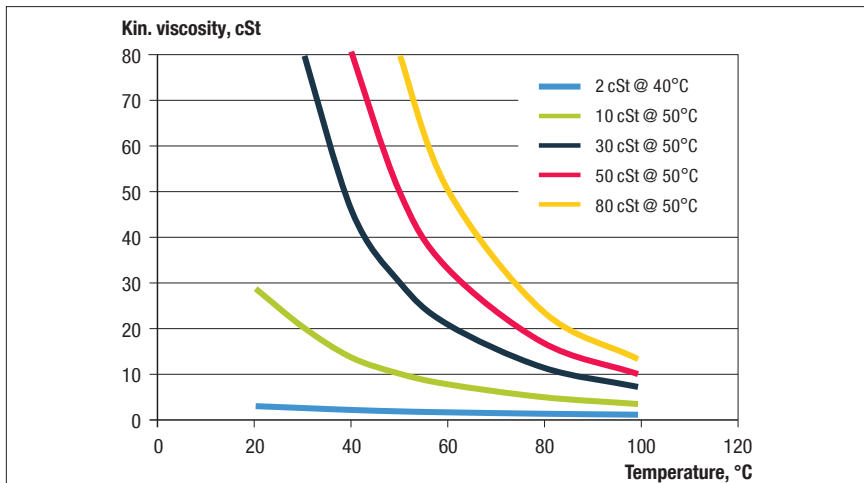

Fig. 5: Temperature – viscosity relationship for low-medium viscosity fuels

The external fuel systems (supply and circulating systems) have a varying effect on the heating of the fuel and, thereby, the viscosity of the fuel when it reaches engine inlet. Today, external fuel systems on-board are often designed to have an optimum operation on HFO, which means that the temperature is kept high. When running on low-viscosity fuels, the temperature of the fuel system must be as low as possible to ensure a suitable viscosity at engine inlet.

Low-viscosity fuels challenge the function of the fuel pump in three ways:

1. Breakdown of the hydrodynamic oil film, which could result in seizures.
2. Insufficient injection pressure, which results in difficulties during start-up and low-load operation.
3. Insufficient fuel index margin, which limits acceleration.

Many factors influence the viscosity tolerance during start-up and low-load operation:

- Engine condition and maintenance
- Fuel pump wear
- Engine adjustment (mainly starting index)
- Actual fuel temperature in the fuel system.



Although achievable, it is difficult to optimise all of these factors at the same time. This complicates operation on fuels in the lowest end of the viscosity range. To build in some margin for safe and reliable operation and to maintain the required viscosity at engine inlet, installation of coolers will be necessary in those fuel systems which do not have these (Fig. 6).

For the very low viscosity distillates, a cooler may not be enough to cool the fuel sufficiently due to the cooling water available on-board. In such a case, installation of a 'chiller' is a possibility. This solution is, however, not used extensively.

The fuel viscosity not only affects the engine fuel pumps. Most pumps in the external system (supply pumps, circulating pumps, transfer pumps and feed pumps for the centrifuge) also need viscosities above 2 cSt to function properly. We recommend contacting the actual pump maker for advice.

#### Fuel pump: drain overflow tank

During normal operation, a small amount of fuel leaks through the main engine fuel pumps. This is clean fuel which, traditionally, is lead back to the HFO settling tank. As the new SECA rules will enforce more operation time on distillates or ULSFO, we recommend

that the drain system is updated to either of the options below and in Fig. 6:

1. Two overflow tanks. One tank with piping leading to the HFO settling tank and one tank with piping leading to the distillate or ULSFO tank.
2. Installing an extra line from the overflow tank. The overflow tank will have piping both to the HFO settling tank and to the distillate or ULSFO tank. The overflow tank has to be emptied before switching to a different fuel.

It is also important to keep the different fuel streams separated, as the fuels

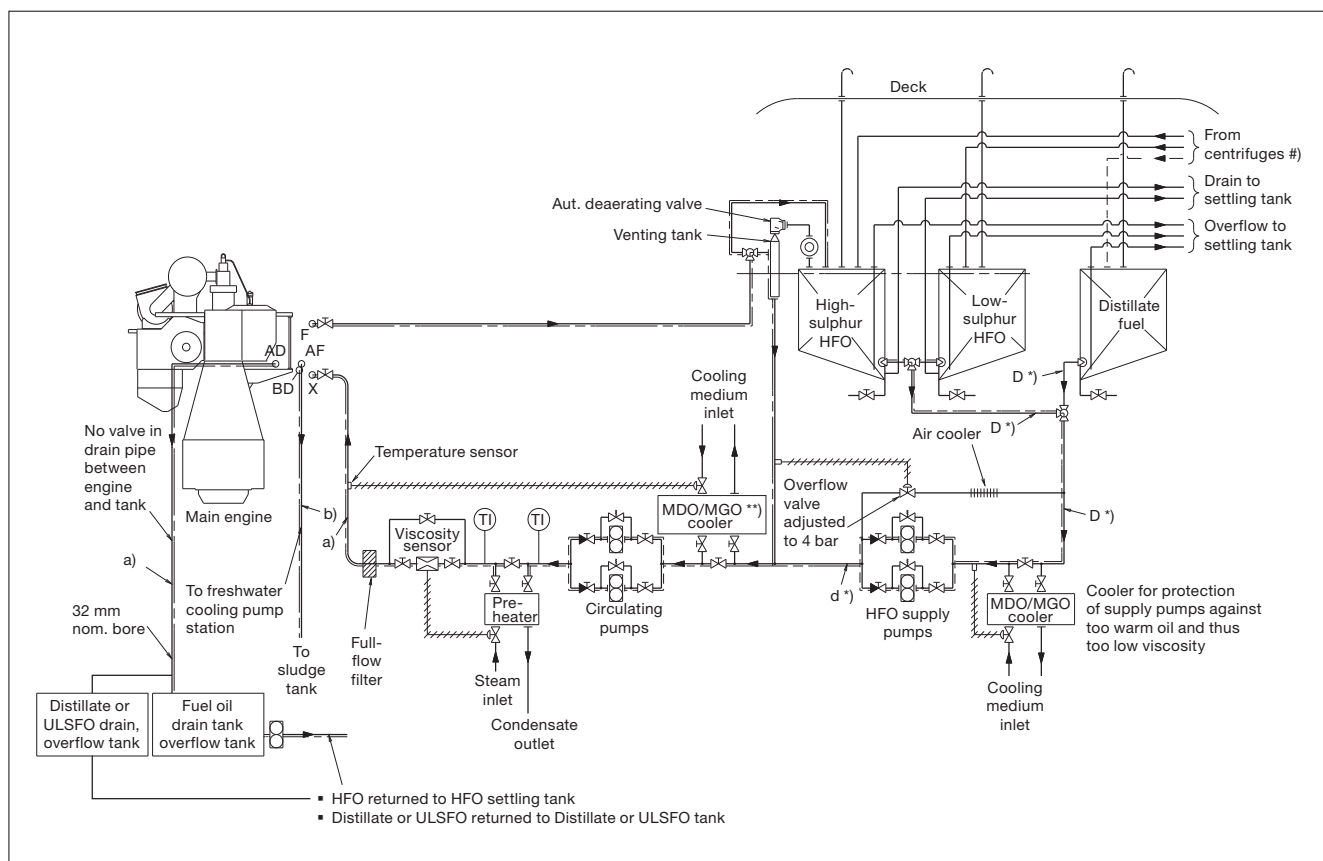

Fig. 6: Fuel system with cooler in the circulating system and also the supply system. Today the pumps in the supply system are made to handle fuels with less than 2 cSt.

might be incompatible. The amount of drain from the fuel pumps will normally be small compared to the amount in the HFO settling tank, so it is not expected that the traditional solution where the fuel pump drain is led to the HFO settling tank will cause serious problems, see also Section 9 regarding compatibility of fuels.

### 5. Fuel pump pressure

The pressure in the fuel pumps must be sufficiently high to open the fuel valves and achieve fuel injection and, thereby, combustion. Worn fuel pumps increase the risk of starting difficulties because the fuel oil pump pressure needed for injection cannot be achieved.

On MC engines and GenSets, an indication of the fuel pump wear can be achieved by reading the actual fuel pump index and compare it with the test-bed measurements. As a rough guideline, we consider the pump worn-out for HFO operation when the index increase is 5-10, or more, under the same conditions as during sea trial. Such fuel pumps should be replaced for better engine performance, and we advise that sufficient spares are kept on board for replacement at sea, if needed.

Due to the design of conventional fuel pumps versus the pressure booster, ME/ME-C/ME-B engines are more tolerant towards low-viscosity fuel compared with the MC/MC-C engines, as illustrated in Figs. 7-8.

It is always advisable to make start checks at regular intervals, and it is a necessity before entering high-risk areas (e.g. ports and other congested areas) where operation on low-viscosity

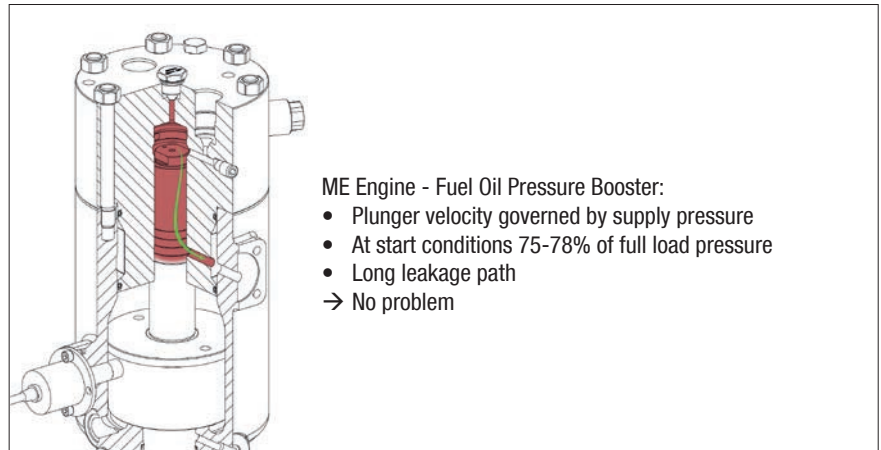

Fig. 7: Fuel pump for ME-engine: start conditions

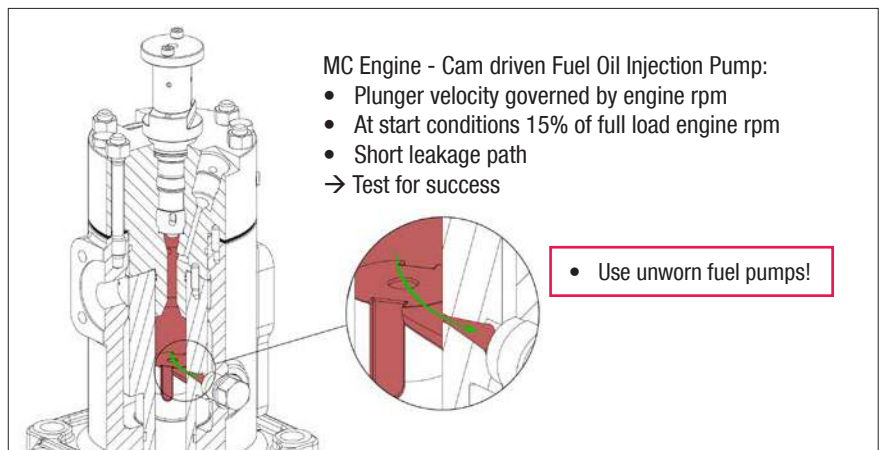

Fig. 8: Fuel pump for MC engine: start conditions

fuel is expected. By such action, the individual low-viscosity limit can be found for each engine with corresponding worn pumps. It is recommended to make a start check twice a year, in the following way:

1. In a safe operation area, change fuel to an available distillate.
2. At different operating conditions, e.g. start, idle, astern and steady low rpm, gradually change the temperature of the fuel at engine inlet, corresponding to viscosities of 3, 2.5 and 2 cSt. Test starting ahead and astern from the control room.

2a. If the engine starts with the specific viscosity as required, then the engine is able to run on fuel with this viscosity level.

2b. If the engine does not start, the starting index in the governor must be adjusted.

A possible outcome of the test may be that the engine requires a higher viscosity than achievable with the systems on-board, due to for example fuel pump wear, engine adjustment and fuel temperature. Furthermore, tests and calculations show that a worn-out fuel

pump for an MC-engine cannot start on a fuel with a viscosity of 2 cSt.

**Summary 4 and 5: viscosity and fuel pump pressure**

- Know what is bunkered
- The viscosity of the fuel should be kept above 2 cSt at engine inlet
- Fuel pumps should be in adequate condition: If not, starting problems could occur, especially on MC engines and GenSets
- Adequate fuel system: check if the necessary cooling equipment is working/installed

**6. Lubricity**

The refinery processes which remove sulphur from the oil also impact the components which give the fuel its lubricity. Most refiners add lubricity-enhancing additives to distillates. Too little lubricity may result in fuel pump seizures. However, MAN Diesel & Turbo does not regard the lubricity of the fuel as a major issue. We have not yet heard of and/or experienced any failure due to the lubricity of the fuel. Our research tests show that we cannot provoke a failure due to lack of lubricity. We do not usually see the need to use lubricity modifiers. However, if there is a genuine challenge, then a lubricity modifier might solve the issue.

MAN Diesel & Turbo has adopted the ISO 8217-2012 lubricity limit: HFRR (high-frequency reciprocating rig) wear scar limit: max 520 µm. We recommend testing the lubricity before using fuels with less than 0.05% sulphur. Independent fuel laboratories can test lubricity according to ISO12156-1.

**7. Cat-fines (Al+Si)**

As in heavy fuel oil (HFO), cat-fines may also be found in fuels with less than 0.1% S (ULSFO, see Section 3). Cat-fines are small, very hard particles from the refining process. They can wear the engine fast, and it is highly recommended to use the fuel cleaning and condition system in an adequate manner to clean the fuel and remove the cat-fines.

The traditional diesel systems on board are dimensioned to operate on low-viscosity fuel at rather low temperatures. Compared to HFO cleaning systems, the separator and preheater are smaller dimensioned and the electrical equipment might not be certified safe equip-

ment. As the viscosity of distillates and ULSFO is very different, it is important to pay attention to the recommended temperature for the different fuel types during the cleaning process, see Table 8.

The cleaning systems must be designed for operation at the higher temperatures and lower recommended flow. Too low a temperature and too high a flow through the separators during cleaning will result in insufficient removal of water, cat-fines, sludge and other contaminants (Fig. 9).

The cat-fine level should be kept as low as possible before the engine inlet, and the maximum level is 10 ppm (Fig. 10).

<u>Fuel type</u>	<u>Min. fuel temperature in the separator</u>
Distillates	40-50°C
ULSFO	98°C
HFO	98°C or higher

Table 8 Recommended fuel temperature for cleaning in the separator

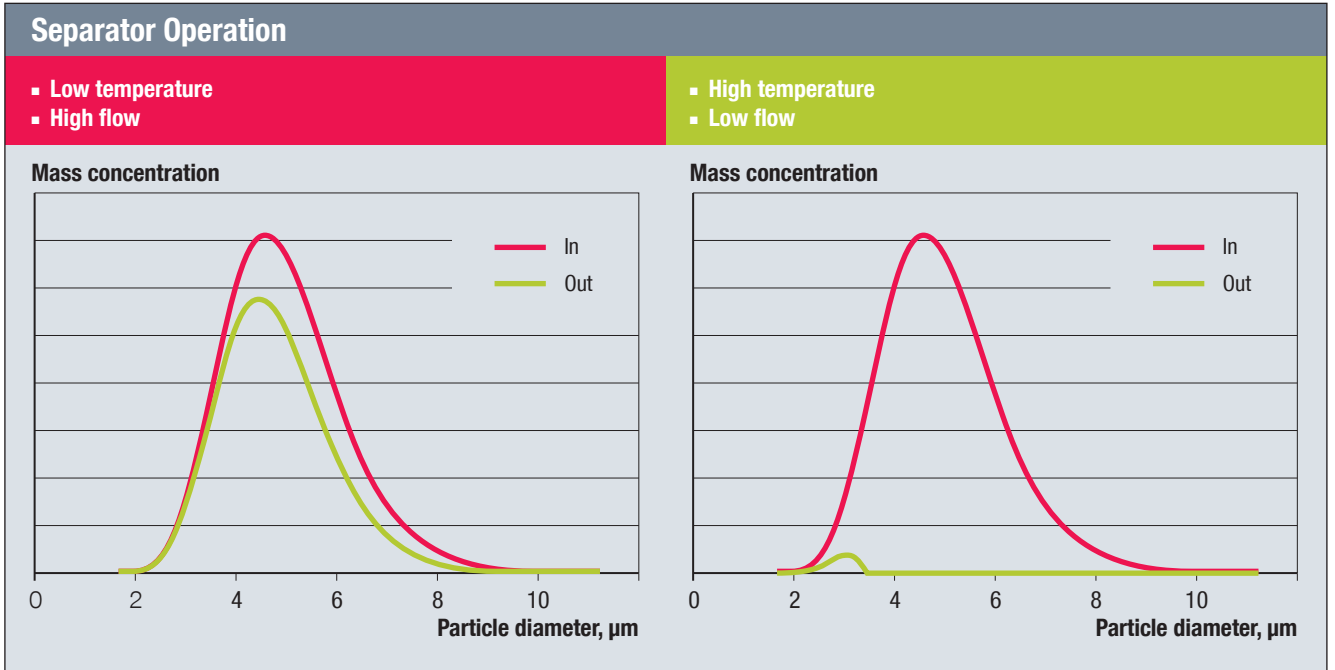

Fig. 9: Separator operations at different parameters. Note the increased cleaning at high temperature and low flow.

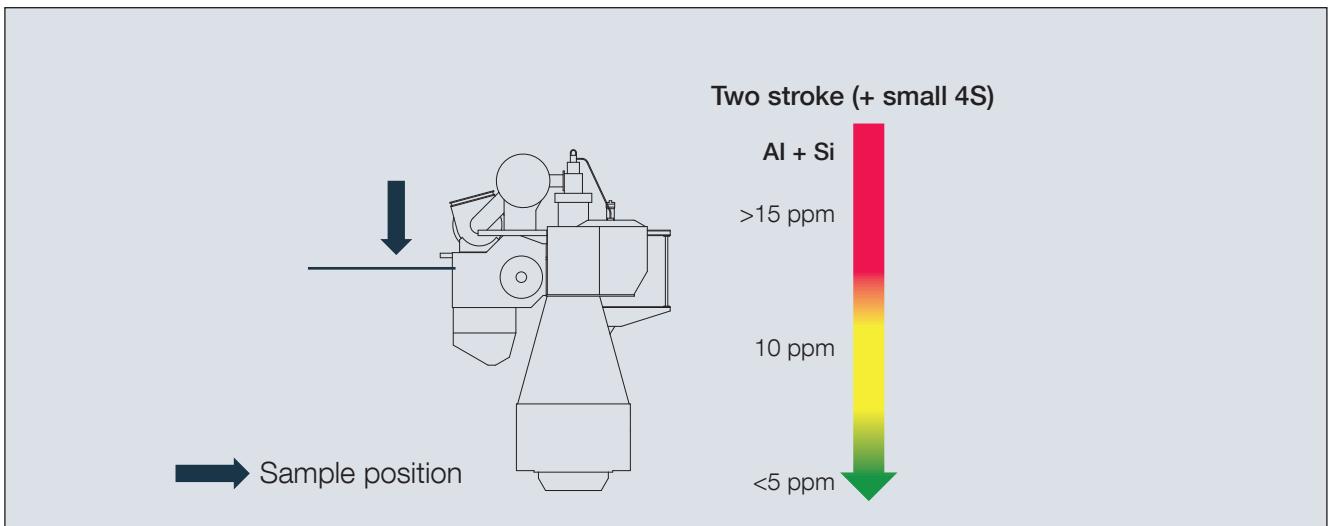

Fig. 10: Recommended maximum content of cat-fines in fuel entering the engine

### 8. Fuel temperature: pour point

The temperature in the tanks and pipes should have a temperature above the pour point of the fuel. If the temperature falls below the cloud point, waxy precipitations might form which could block filters and other equipment, and if the temperature falls below the pour point then the fuel cannot flow (Fig. 11).

If the fuel is reheated to above the cloud point, the waxy precipitations will dissolve again, and if the fuel is reheated to above the pour point the fuel will be able to flow again. However, this will require proper distribution of the heat and good recirculation of the fuel in the tanks and systems. This means that the fuel should be heated either in the tanks or by re-circulating it through an external heater (Fig. 12). A severe case of waxy precipitations may be seen in the photo in Fig. 13.

### 9. Compatibility between fuels

Compatibility issues arise when the components in the fuels do not mix well together, for example, when mixing fuels with a high aromatic hydrocarbon content (asphaltenes), such as in HFO, with fuels of the more aliphatic/paraffinic type, for example distillates or the new types of 0.1% S fuels (ULSFO). The asphaltenes might drop out of the suspension and the result can be vast amounts of sludge in tanks, filters and separators.

Some of these fuels can also have a cleaning effect on the tanks. Sludge from residual fuels build up over time in the tanks, and some of the new fuels will be able remove and carry the sludge. The sludge may then be trapped in the filters further down in the fuel treatment

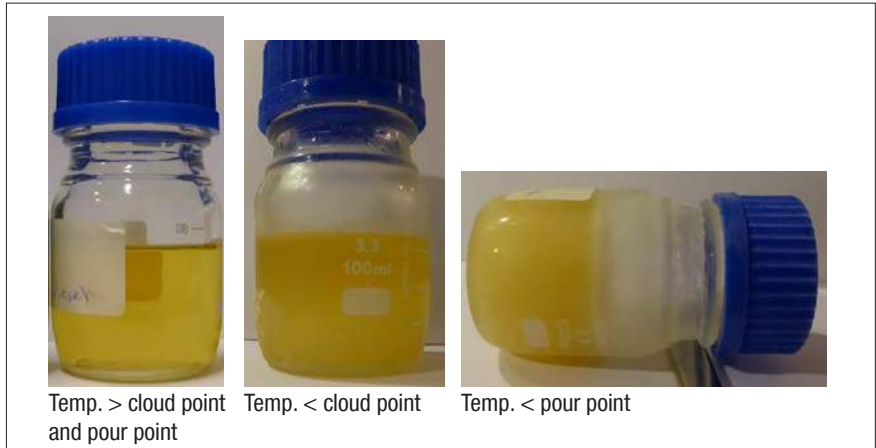

Fig. 11: Photos of a distillate sample at different temperatures

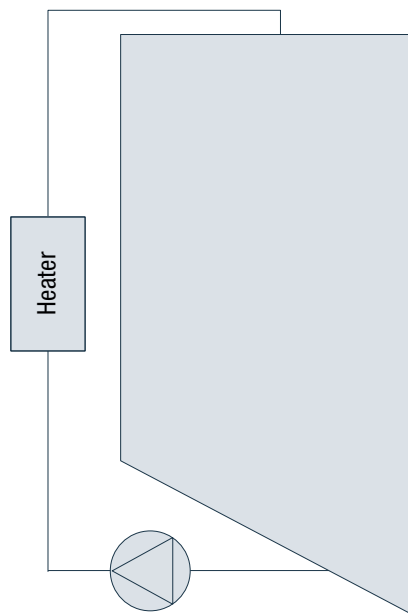

Fig. 12: Schematic example of tank configuration: re-circulating the fuel and heating it by an external heater



Fig. 13: Waxy precipitations in a fuel sample

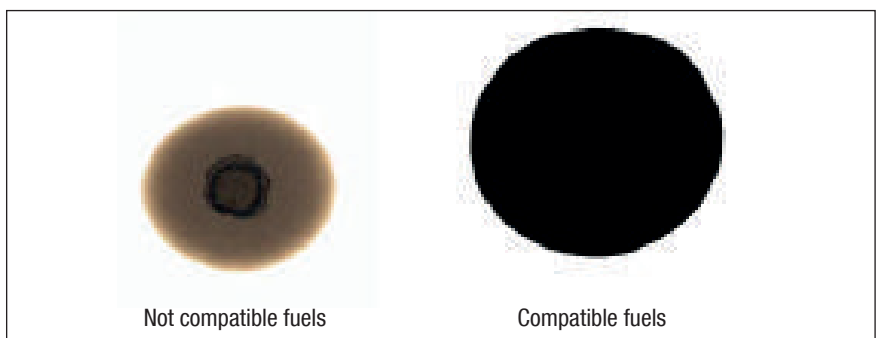

Fig. 14: Spot test: photos of mixture of two different fuels on filter paper (courtesy Chevron)

system, see Section 4 regarding drain from the fuel pumps.

The risk of encountering incompatibility issues can be reduced by checking the compatibility between the fuels before bunkering. This can be done manually with a kit on board (Fig. 14), or via an independent laboratory. The latter often being a slow process, since the ship will have left the port before the laboratory returns with the test result.

Consequently, we recommend that different kinds of fuels are not mixed, and that dedicated tanks are used for different types of fuel. Of course, the different fuels will mix in the fuel system when switching fuels, e.g. from high sulphur HFO to fuels with less than 0.1% S, and we recommend that care must be taken during this operation.

**Summary 6, 7, 8 and 9: lubricity, cat-fines, pour point and compatibility**

- Know what is bunkered
- Inform the crew of specific challenges
- Lubricity is not considered a major issue
- Keep the fuel temperature above the pour point (heated tanks might be necessary)
- Keep the right fuel in the right tank to avoid compatibility issues. Check compatibility!
- Clean the fuel and remove cat-fines: use the correct temperature on the centrifuges to ensure maximum removal of cat-fines (max. limit 10 ppm).

## 10. Fuel change-over procedures

This section only describes the change-over between HFO and distillates or ULSFO. Change-over to LNG, methanol, ethane or LPG takes place in a separate fuel system and, therefore, does not face the same challenges.

High-sulphur HFO is used at high temperatures to reduce the viscosity to the required level before the engine inlet. Distillates are often used at rather low temperatures to keep the viscosity sufficiently high before the engine inlet. A change-over between the fuels will mean a change-over from high temperature to low temperature, or from low to high. The new ULSFO will often be used at medium temperatures, thereby reducing the challenge of the large temperature difference.

The injection equipment needs to be protected against rapid temperature changes, as the large temperature changes might otherwise cause sticking or scuffing of the fuel valves, fuel pump plungers or suction valves. The change-over must be carried out at a low load (25-40% MCR) and in a controlled manner, and the fuel temperature gradient must not exceed 2°C/min, see also Figs. 15 and 16.

Special care must be taken when going from a low-viscosity fuel, which is cold, to a high-viscosity fuel, which needs to be heated. When the warm fuel runs to the cold components, they will warm up, and the material will expand slightly. For example, the fuel plunger will warm up first, whereas the barrel contains more material and, therefore, its expansion will take longer time, which means that the clearance will decrease and thereby increase the risk of seizures. Changing the other way around, from warm to cold fuel, is less sensitive, as the plunger will cool down first, reduce in size and, thereby, increase the clearance and lower the risk of seizures.

It is advisable to practise the change-over in deep waters before entering high-risk areas such as ports and other congested areas. The complete change-over procedure can be found in the operation manuals.

SafeChange Controller with Diesel-switch may be installed and used for automatic fuel change-over. This will enable change-over at loads up to 75%. Contact MAN PrimeServ for more information on installation of SafeChange Controller with Diesel-switch (e-mail: Primeserv-cph@mandieselturbo.com).

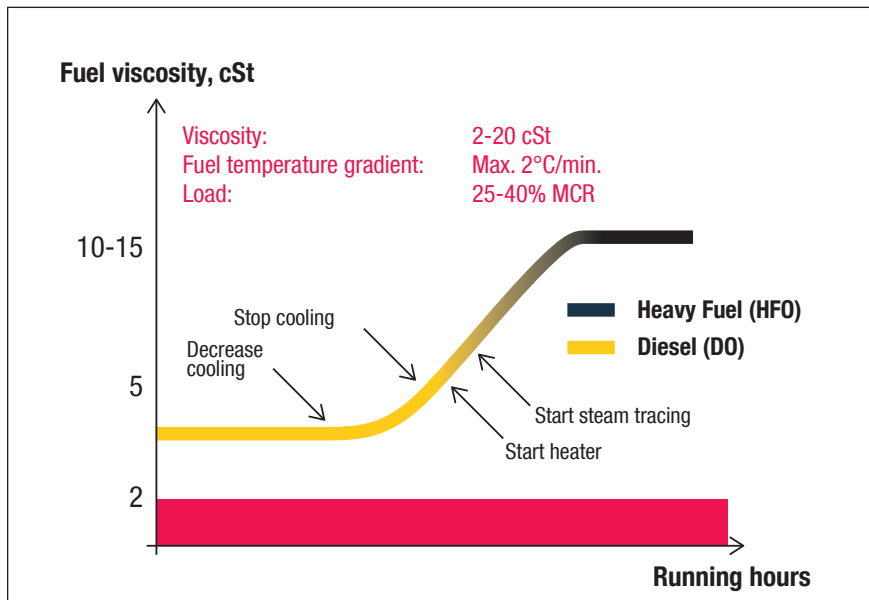

Fig. 15: Change-over procedure from cold, low viscosity fuel (e.g. diesel) to warm, high viscosity fuel (e.g. HFO)

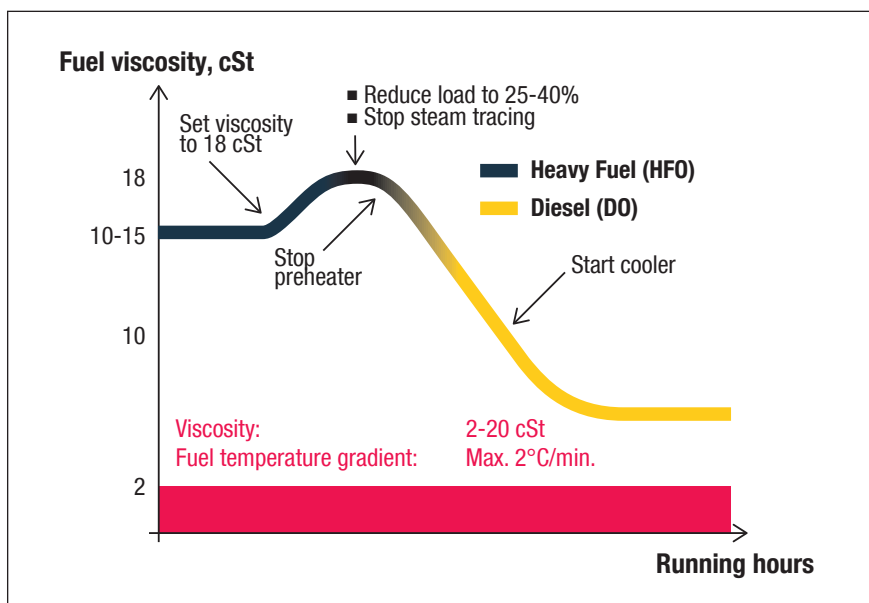

Fig. 16: Change-over procedure from warm, high viscosity fuel e.g. HFO to cold, low viscosity fuel (e.g. diesel)

As mentioned above, the new ULSFO types will often be used at medium temperatures to reduce the challenge of the large temperature difference. However, similar care must be taken

when changing over to and from these types of fuel and the maximum temperature gradient during change-over must be kept at 2°C/min.



**Summary 10:  
fuel change-over**

- Know what is bunkered
- Have adequate training and procedures
- Change-over procedure can be found in the operation manual
- The change-over must be carried out at a low load (25-40% MCR)
- Fuel temperature gradient must not exceed 2°C/min
- Be cautious when switching fuel: follow the procedures and monitor temperature and viscosity

## 11. Low-sulphur biofuel

MAN B&W two-stroke engines can run on fuels which are within the ISO 8217 limits. However, they are also capable of running on crude biofuel, tallow, rapeseed oil and other kinds of biofuels (refer to Stationary MAN B&W MC-S Engines for Biofuel Applications, 5510-0098-00ppr Sep 2010). Blends of ordinary petroleum-based fuels and biofuels, such as fatty acid methyl esters (FAME) should not impose any larger issues if the blends are stable and do not produce large amounts of sludge. However, there are factors to take into consideration before bunkering and using fuel containing biofuel in order to ensure a safe and reliable operation.

The cylinder oil used should be matched with the sulphur content in the fuel. A cylinder oil with 15-40 BN should be utilised when operating on 0.1% S biofuel. The cylinder condition should, as always, be monitored carefully, see Section 1 and SL2014-587.

Biofuels can contain organic acids that may cause corrosion in the fuel system. It is therefore important to measure the acid number (AN, ASTM D664). Distillate fuels usually have acid numbers below 0.5 mg KOH/g, and heavy fuel oil (HFO) usually has less than 2.5 mg KOH/g. For special applications, and if the intention is to utilise fuels with a very high AN, the materials in the fuel injection system must be changed to anti-corrosive materials. In such a case, the AN has to be below 25 mg KOH/g.

Ash content and potential abrasive components such as silicates are factors to take into account before using biofuel. A high ash content could present severe operational issues in systems after the engine. Abrasive materials entering the engine will increase the wear of liners and pistons.

Before using low-sulphur biofuel on Holeby GenSets, please consult MAN Diesel & Turbo.

### Biodiesel

There are various biofuels on the market today. One of the more common is biodiesel. Biodiesel is for example used either as pure biodiesel or is mixed with diesel intended as fuel for the automotive market. Biodiesel is defined as fatty acid methyl esters (FAME) produced from renewable sources of vegetable oils such as rapeseed oil, soybean oil, used frying oil and animal fats that meets international specifications for a B100 such as ASTM D6751 and EN-14214. The flash point limit for B100 is 130°C, and thereby acceptable for marine use. Occasionally, marine diesel oil (MDO) and marine gas oil (MGO) can contain FAME because diesel in-

tended for the automotive market has been blended in the marine products. Fuel blended with biodiesel can most certainly burn when reaching the engine. However, issues may arise in the fuel system due to acidic compounds in the fuel. Pumps, filters and separators could also be affected. Compatibility and microbial growth during storage might also be issues, which is also true for other types of biofuel. For more information on handling marine fuels with FAME, please refer to CIMAC Guideline handling marine fuels with FAME V1.0, 2013. The current ISO 8217-2012 states that the fuel shall be free from bio-derived materials other than “de-minimis” levels of FAME and that blending of FAME should not be allowed.

**Summary 11 and 12: low-sulphur biofuel and biodiesel**

- MAN B&W engines can run on biofuel, but there are factors to consider before use
- High acid numbers (AN), ash content, abrasive materials
- Storage considerations: compatibility and microbial growth
- Change to a low-BN cylinder oil (15-40 BN)
- Inform the crew about potential challenges
- Monitor the cylinder condition
- ISO 8217-2012: the fuel shall be free from bio-derived materials



## 12. Summary

Below is given a short summary of the recommendations in this guide:

- Know what is bunkered
- Inform the crew regarding specific challenges
- Have adequate training and procedures
- Use appropriate cylinder oils and evaluate the feed rate
- Use low-BN oil for low-sulphur fuel
- Use high-BN oil for high-sulphur fuel
- Fuel pumps should be in adequate condition, if not, starting problems could occur, especially on MC engines
- Adequate fuel system: check if the necessary cooling equipment is working/installed
- The right fuel in the right tank to avoid compatibility issues. Check compatibility!
- Clean the fuel and remove cat-fines
- Use the correct temperature on the centrifuges in order to ensure maximum removal of cat-fines
- Be cautious when switching fuel: follow the procedures and monitor temperature and viscosity

For any questions or inquiries regarding the recommendations in this paper, please contact our Operation Department at the e-mail address: [leo@mandieselturbo.com](mailto:leo@mandieselturbo.com)

## Appendix

The various oil suppliers offer cylinder oils with a broad range of BN levels. Our MAN B&W engine design is based on the 70 BN oil traditionally used, however, as new oil products have been introduced, BN levels have changed.

When switching to a different BN level, we scale the ACC factor to the new BN level by multiplying the ACC factor with the ratio between the new oil BN and the previous known oil BN.

$$\text{Cylinder lube feed rate} = \text{ACC} \times \%S_{\text{fuel}} = \text{FRF} \times \%S_{\text{fuel}}$$

For example, if a 25 BN oil is used for a 0.75 % S fuel in an engine normally operating at an ACC or a feed rate factor of 0.34 g/(kWh x %S) for a 70 BN oil:

$$\text{ACC}_{70} = \text{FRF}_{70} = 0.34 \frac{\text{g}}{(\text{kWh} \times \%S)}$$

$$\text{ACC}_{25} = \frac{25}{70} \times \text{ACC}_{70} = \frac{25}{70} \times 0.34 \frac{\text{g}}{(\text{kWh} \times \%S)} = 0.95 \frac{\text{g}}{(\text{kWh} \times \%S)}$$

$$\text{Feed rate} = \text{ACC} \times \%S = \text{ACC}_{25} \times \%S = 0.95 \frac{\text{g}}{(\text{kWh} \times \%S)} \times 0.1\%S = 0.095 \frac{\text{g}}{\text{kWh}}$$

The 0.095 g/kWh feed rate is less than the basic feed rate of 0.6 g/kWh, and in this case the basic feed rate should be used.

$$\text{Basic feed rate} = \text{minimum feed rate} = 0.6 \text{ g/kWh}$$

When changing to a new oil brand or type, the ACC factor may need to be reassessed as described above, starting with an ACC factor in the upper range. After this, a gradual reduction can be carried out based on actual conditions observed or the sweep test.